



MODEL ADC 125/16

“VME” DUAL CHANNEL, HIGH PERFORMANCE, 125Mhz, 16 BIT ADC DAUGHTER BOARD

DESCRIPTION:

The **JOERGER ENTERPRISES, INC.** Model ADC 125/16 is a dual channel, high performance 125Mhz, 16 bit ADC daughter card to be used with the VME-M series motherboard. To insure this performance the ADC clocks are driven with a special clock generator chip. It uses a PLL and high-speed VCO to generate the actual ADC clock with a typical clock jitter of 300fseconds rms. Often overlooked clock jitter is a critical factor at this speed and resolution. The clock chip uses the standard on board crystal clock as its basic source and this programmed array to generate a pair of ADC clocks one for each ADC. In situations where either an external clock is needed or the use of an on board crystal oscillator on the daughter card may be best both these options are selectable.

The signal inputs are 50 ohms and AC coupled. It uses a balun transformer and a wide band amplifier with a gain of ten. It provides a selectable input range of either 150mv or 225mv p-p so low-level signals can be accepted without the use of an external amplifier. The input bandwidth of the amplifier and the ADC is 5Mhz to 140Mhz. This feature provides the ability to digitize the input over that bandwidth. So in addition to digitizing it can also under sampling on signal inputs with a carrier frequency of up to 140Mhz. A future model is being developed that will increase this input bandwidth to over 300Mhz.

Standard triggering is from the motherboard. However an external trigger directly to the daughter card may better satisfy a requirement. This feature is offered as an option.

A Model VME-M1 motherboard can accept one of these daughter cards offering two digitizer channels. A Model VME-M4 can accept 4 cards. This would provide 8, 125Mhz, 16-bit digitizers in a single 6U VME slot.

APPLICATIONS:

High Performance Instrumentation
Telecommunications
Receivers
Spectrum Analysis
Imaging Systems
ATE

FEATURES:

INPUT

- Range 150mv/ 225mv, p-p, selectable
- Input Impedance 50 ohms, AC coupled
- Total Input signal Bandwidth 5Mhz to 140Mhz
- ADC Sampling speed 1Mhz(min) to 125Mhz(max)
- Clock Time Jitter 300 fs rms typical
- Resolution 16 bits
- SNR 75db
- INL +/- 1.2 LSB typical
- DNL +/- .3 LSB typical

OPTIONS

- External Trigger Input Negative TTL signal, 500 ohms
- External Clock Input TTL, 50 ohms
- On Board Crystal Oscillator

CONNECTORS

SMA

POWER REQUIREMENTS:

+ 3.3V. +5V

SIZE:

Single width daughter card

FUTURE OPTION:

Bandwidth, 5-300Mhz

work/datasheets/ADC125A.doc

04/08



51 IDLE DAY DRIVE, CENTERPORT, NY, 11721, USA

1-631-239-5579 • FAX 1-815-642-8604 • Email: joerger@joergerinc.com • web: www.joergerinc.com

INPUT 1

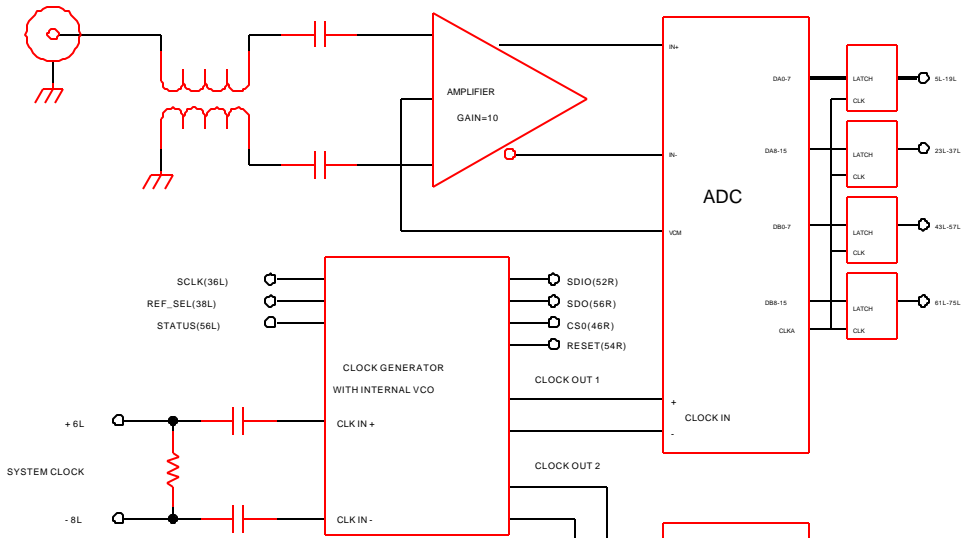

INPUT 2

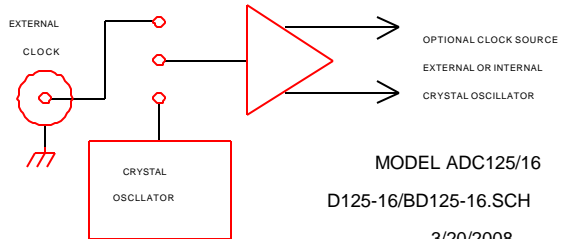
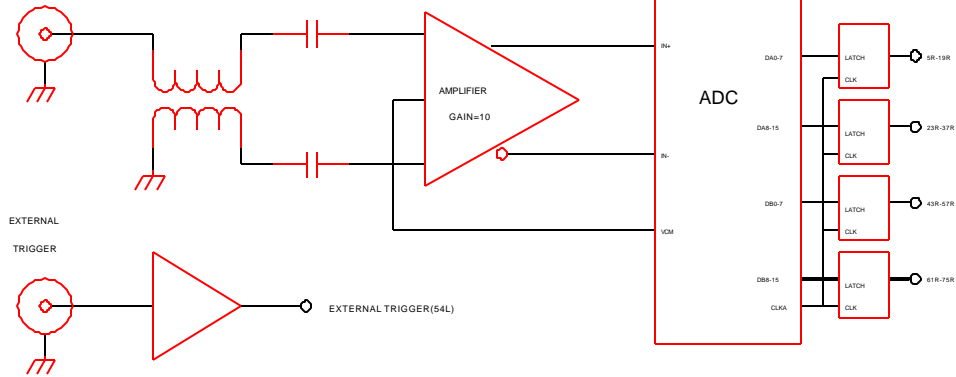

ARRAY PROGRAM CHIP

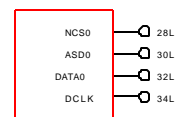

MODEL ADC125/16
D125-16/BD125-16.SCH
3/20/2008